

SYC

Manual Stacker

Model No.			SYC 05-16	SYC 10-16	SYC 15-16	SYC 20-16	SYC 10-30
Mast			Single mast				2-Stage mast
Rated capacity	Q	kg	500	1000	1500	2000	1000
Load center	C	mm	400	400	400	400	400
Min. Height of forks	h	mm	85	90	90	90	95
Lifting height	H	mm	1600	1600	1600	1600	3000
Fork length	L	mm	800	900	900	900	900
Fork width	E	mm	750	220-950	220-950	220-950	220-900
Min. Turning radius	R	mm	1110	1250	1250	1250	1250
Front load wheel		mm	ø74x70	ø74x70	ø74x70	ø74x70	ø74x70
Rear wheel		mm	ø180x50	ø180x50	ø180x50	ø180x50	ø180x50
Overall length	A	mm	1280	1380	1380	1380	1340
Overall width	B	mm	800	1000	1000	1000	950
Overall height	H1	mm	1980	2100	2100	2100	2060
Net weight		Kg	155	255	265	290	370

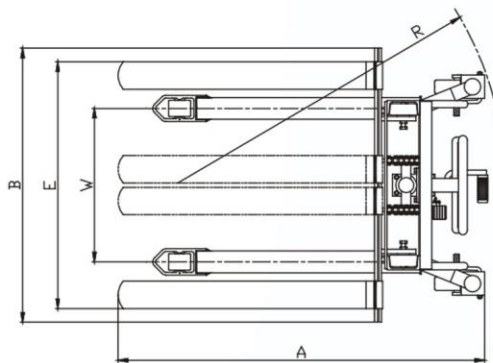
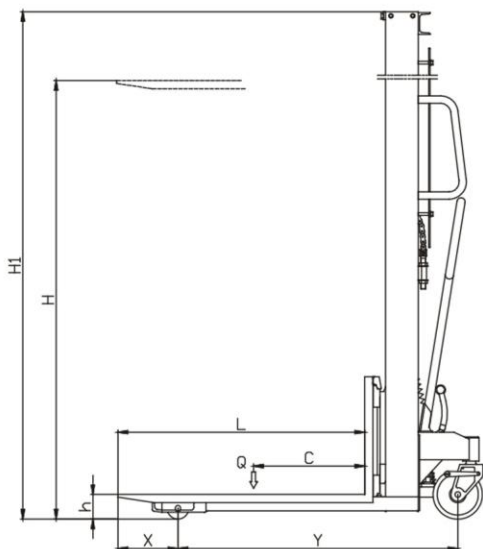

PT. NATRACO TUNAS CITRA

021 6260083 - 0818 0825 1688

admin.awp@natraco.co.id

Jl. Kerajinan No. 8, Jakarta Barat