



SJ85 AJ ARTICULATING BOOM

STANDARD FEATURES

- Axle based 4WD system
- Operator controlled locking rear differential and limited slip front differential
- Oscillating axle
- Drivable at full height
- EasyDrive™ direction sensing drive and steer controls
- SpeedyReach™ functionality
- SkyRiser™ functionality
- 360° continuous turret rotation
- 45% Gradeability
- Secondary Guarding (SGE)
- Deutz TD2.9L4 diesel engine
- Swing out engine tray
- Swing up cowlings
- Modular platform railing system
- Tri-entry sliding mid-rails
- 110V AC outlet on platform with GFI
- Proportional controls
- Relay based control system
- Color coded and numbered wiring
- Hourmeter
- Operator horn
- Overload sensing system
- All motion alarm
- Tie down/lifting lugs
- Wet disc SAHR brakes (front and rear axle)
- 18 x 625 grip lug foam-filled tires
- Telematics ready
- 2 Year Gold Leaf Warranty (5 year structural warranty)

ACCESSORIES AND OPTIONS

- 36 x 72" Platform
- Perkins 404F-E22TA diesel engine
- Kubota WG3800 dual fuel engine
- 3.5 kW generator (includes hydraulic oil cooler)
- Welder ready package (includes 12 kW generator, hydraulic oil cooler, 3 phase power connection in platform, and welder mount.)
- Welder package (includes 12 kW generator, hydraulic oil cooler, 3 phase power connection in platform, welder mount and Lincoln V275-S welder)
- Cold weather start kit (Recommended for regions where average monthly low temperatures can reach 14°F / -10°C (Includes cold start engine oil, battery blanket, hydraulic tank heater, and engine load kit (Deutz TD2.9L4))
- Arctic weather package (Recommended for regions where average monthly low temperatures can reach -0.4°F / -18°C (Includes arctic engine oil, battery blanket, hydraulic tank heater, engine load kit (Deutz TD2.9L4), block heater, arctic hydraulic oil, arctic platform rotator and arctic gear oil in the axles and swing drive Glow plugs, arctic hydraulic hoses (all), and oversized foot switch cover are also included (standard equipment).)
- Extra propane tank and bracket (dual fuel only)
- Hydraulic oil cooler
- Flashing light
- 1/2" airline to platform
- Positive air shut-off valve (Deutz engine only)
- Hostile environment package (Includes cylinder bellows, boom wipers, covers for the fly boom cutouts, and control box cover)
- Auxiliary top rail (36 x 96" platform only)
- Control box cover
- Platform work lights
- Pipe rack
- Tool caddy
- Side gate
- Bio oil
- Non destructive testing
- Warranty Options (3 year or 5 year plans available)

TIRE OPTIONS

- Grip lug foam-filled non marking tires

† Capacities, and machine weights may differ when options are added.

‡ Certain option pricing not available at time of printing.

Preliminary specifications at time of printing. Standard lead times may be increased when optional equipment is added, consult factory.

SJ85 AJ ARTICULATING BOOM

Dimensions	SJ85 AJ
Work Height	91' (27.74 m)
Platform Height	85' (25.91 m)
Horizontal Reach	56' (17.07 m)
Up and Over Height	34' (10.36 m)
A Platform Size	36" x 96" (0.91 x 2.4 m)
B Stowed Width	8' 2" (2.49 m)
C Tailswing	3' (0.91 m)
D Stowed Height	8' 9" (2.67 m)
E Transportation Height	9' 6" (2.90 m)
F Stowed Length	38' 2" (11.63 m)
G Transportation Length	32' 10" (10.00 m)
H Wheelbase	9' 4" (2.84 m)
I Ground Clearance	13" (0.34 m)

Specifications	SJ85 AJ
Rotation	360°
Platform Rotation	170°
Jib Length	5' 6" (1.68 m)
Jib Range +/-	+65° / -60°
Weight	37,400 lbs (16,965 kg)
Gradeability	45%
Turning Radius (Inside)	10' (3.05 m)
Turning Radius (Outside)	20' 5" (6.22 m)
Axle Oscillation	4" (10.16 cm)
Drive Speed (High speed)	3 mph (4.8 km/h)
Capacity	500 / 750 lbs (227 / 340 kg)
Maximum # of Persons	2 / 3
Tire Type	Grip lug foam-filled
Tire Size	18-625
Diesel Engine	74 HP
Fuel Tank Capacity	30.4 gal. (115 L)
Hydraulic Reservoir	45 gal. (170 L)

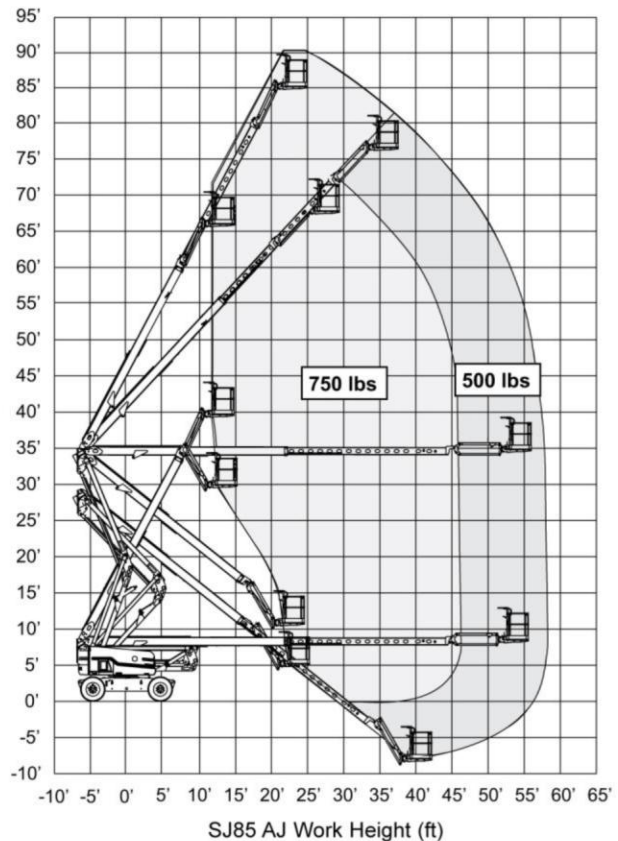
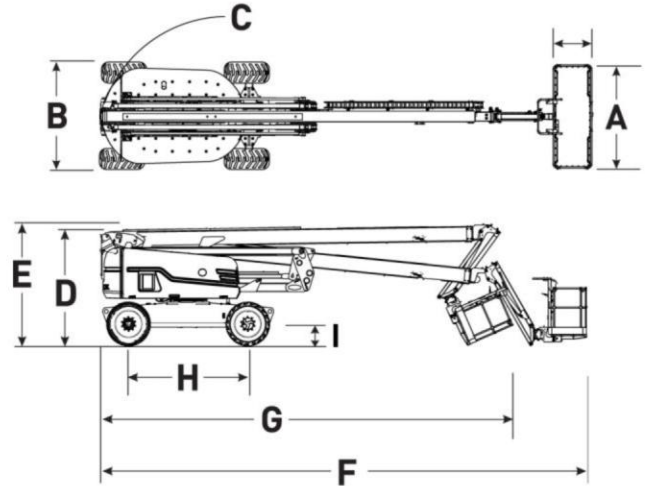

PT NATRACO TUNAS CITRA

Jl. Kerajinan No. 8, Jakarta - 11130

Phone : (021) 6260083, 6313333

Fax : (021) 6394243

Email : admin.awp@natraco.co.id

Website : natraco.co.id

This brochure is for illustrative purpose only and based on the latest information at the time of printing. Skyjack Inc. reserves the right to make changes at any time, without notice, to specifications, standard and optional equipment. Consult the Operating Maintenance and Parts Manuals for proper procedures. Work platforms have been tested to comply with ANSI and CSA standards as interpreted by Skyjack Inc.

