

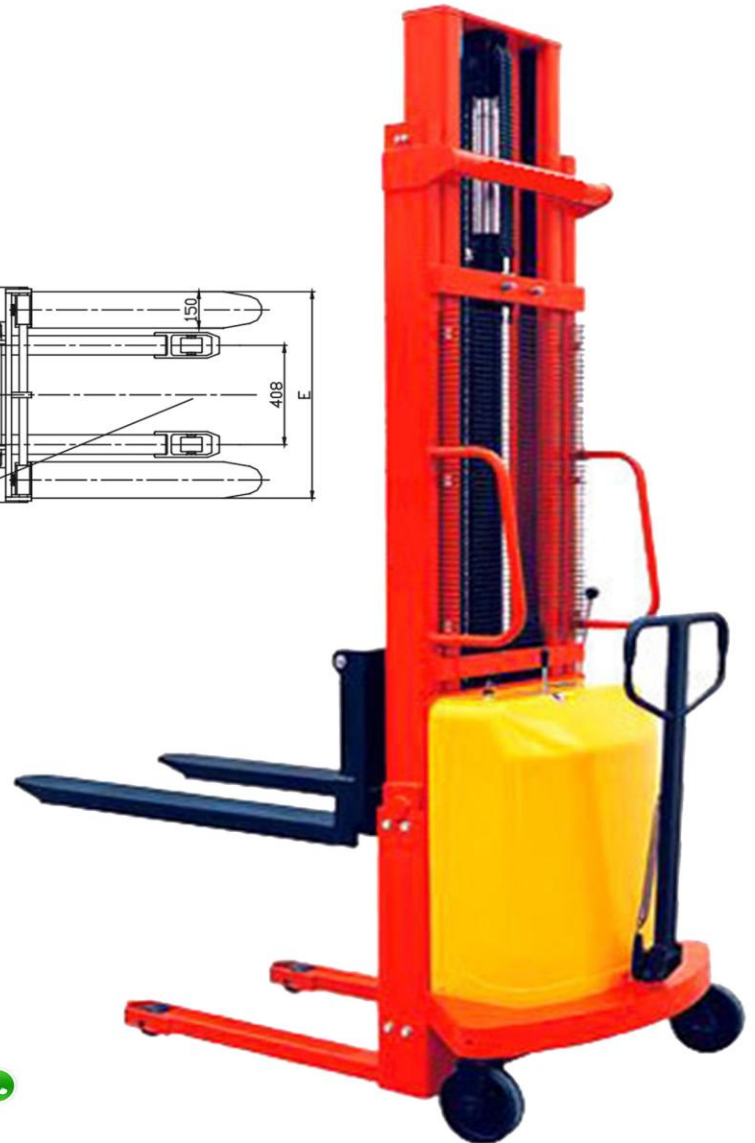

Semi Electric Stacker

Model No.		DYC 10-16	DYC 15-16	DYC 20-16	DYC 10-20	DYC 10-25	DYC 10-30	DYC 10-35	DYC 15-20	DYC 15-25	DYC 15-30	DYC 15-35	DYC 20-20
Rated capacity	Q	kg	1000	1500	2000	1000	1000	1000	1000	1500	1500	1500	2000
L Load center	C	mm	400	400	400	400	400	400	400	400	400	400	400
Mast			Single mast				2-stage mast						
Lifting height	H	mm	1600	1600	1600	2000	2500	3000	3500	2000	2500	3000	3500
Max. Machine height	H2		2060	2060	2060	2560	3060	3560	4060	2560	3060	3560	4060
Fork length	L	mm	1000	1000	1000	1000	1000	1000	1000	1000	1000	1000	1100
Fork width	E	mm	300-850	300-850	300-850	300-680	310-820	310-820	310-820	310-820	310-820	310-820	330-640
Min. Turning radius	R	mm	1350	1350	1350	1350	1350	1450	1450	1350	1350	1450	1280
Wheel base	Y	mm	1180	1180	1180	1185	1185	1185	1185	1185	1185	1185	1185
Front-wheel distance	X	mm	322	322	322	316	316	316	316	316	316	316	316
Lifting motor	V/Kw		12/1.5-1.6	12/1.5-1.6	12/1.5-1.6	12/1.5-1.6	12/1.5-1.6	12/1.5-1.6	12/1.5-1.6	12/1.5-1.6	12/1.5-1.6	12/1.5-1.6	12/1.5-1.6
Battery	V/Kh		12/120	12/120	12/120	12/120	12/120	12/120	12/120	12/150	12/150	12/150	12/150
Charger	V/Kh		12/15	12/15	12/15	12/15	12/15	12/15	12/15	12/15	12/15	12/15	12/15
Overall length	A	mm	1670	1670	1670	1670	1670	1700	1700	1670	1670	1700	1600
Overall width	B	mm	865	865	865	810	810	930	930	810	810	930	710
Overall height	H1	mm	2060	2060	2060	1580	1830	2080	2330	1580	1830	2080	1580
Net weight		kg	350	365	390	425	450	470	490	450	475	495	470

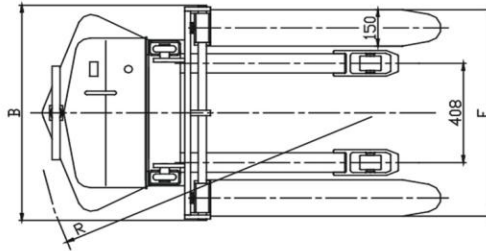
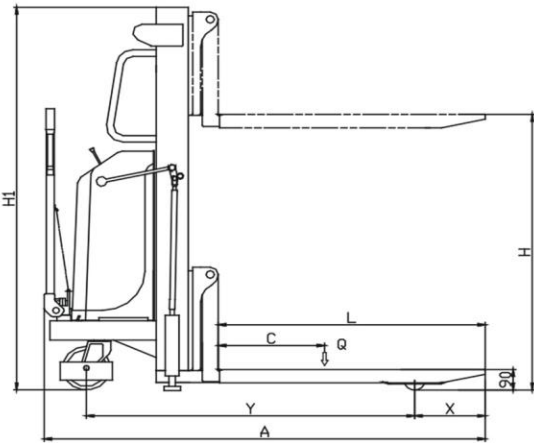

PT. NATRACO TUNAS CITRA
 021 6260083 - 0818 0825 1688
 adm@natracomaterialhandling.com
 Jl. Kerajinan No. 8, Jakarta Barat